



VACUUM SEALER SU-604CC

Floorstanding unit. 40 m³/h. 465 + 465 mm.



FOOD PRESERVATION AND SOUS-VIDE
COMMERCIAL VACUUM PACKING MACHINES

SALES DESCRIPTION

Two sealing bars 465 + 465 mm.
40 m³/h Busch vacuum pump.
Vacuum controlled by sensor.

- ✓ Powered by Busch.
- ✓ Vacuum controlled by sensor.
- ✓ Vacuum PLUS.
- ✓ LCD colour screen: all information at a glance.
- ✓ Backlit touch keyboard.
- ✓ Programmable: 99-programme memory. Blocking option.
- ✓ "Pause" button to marinate food.
- ✓ Phased vacuum programme.
- ✓ Detection of the evaporation of liquids.
- ✓ Double seal.
- ✓ Cordless sealing bar.
- ✓ Bag sealing program.
- ✓ Progressive decompression.
- ✓ Vac-Norm ready with automatic decompression.
- ✓ Stainless steel body and chamber.
- ✓ Damped transparent lid.
- ✓ Dry-oil programme for drying the pump.
- ✓ Working hours counter for oil changes.
- ✓ Safety system with protection against vacuum failure.
- ✓ NSF-listed model.

INCLUDES

- ✓ BUSCH pump.
- ✓ Sensor controls.
- ✓ Programmable.
- ✓ Bluetooth connectivity.
- ✓ Vacuum PLUS: up to 10 seconds of extra vacuum pull.
- ✓ Soft air function.
- ✓ Clear methacrylate lid.
- ✓ "PAUSE" function.
- ✓ Liquid detection system.
- ✓ Dry oil cycle.
- ✓ NSF approved.
- ✓ Filling plate.

OPTIONAL

- Inert gas.
- Printer.
- Vacuum packing bags.
- External vacuum kit for Vac-Norm, containers and accessories.
- Bag cutting kit.
- Support for liquid packaging.
- Additional filling plates.

ACCESSORIES

- Bag cutting kits
- Filling plates
- Liquid insert plates
- Vac-norm external vacuum kit
- Vac-norm containers
- Smooth bags for vacuum packing
- Thermal labels for CG2 / RB printer
- RB desktop printer for SU vacuum packing machines
- Thermal transfer labels for RB printer
- Vacuum packing machines maintenance kits

SPECIFICATIONS

Pump capacity: 40 m³/h
Pump capacity (60 Hz): 48 m³/h
Bar length: 465 + 465 mm
Total loading: 1100 W
Vacuum pressure (maximum): 0.5 mbar

Internal dimensions

- ✓ Width: 672 mm
- ✓ Depth: 481 mm
- ✓ Height: 200 mm

External dimensions (W x D x H)

- ✓ Width: 740 mm
- ✓ Depth: 566 mm
- ✓ Height: 997 mm
- Net weight: 145 kg
- Background noise: 32 dB(A)
- Crated dimensions
830 x 670 x 1200 mm
- Gross weight: 182.8 kg





VACUUM SEALER SU-604CC

Floorstanding unit. 40 m³/h. 465 + 465 mm.



AVAILABLE MODELS

1140820	SU-604P CC 230-400/50/3N
1140821	SU-604GP CC 230-400/50/3N
1140833	SU-604GP CC 208-240/60/3

* Ask for special versions availability

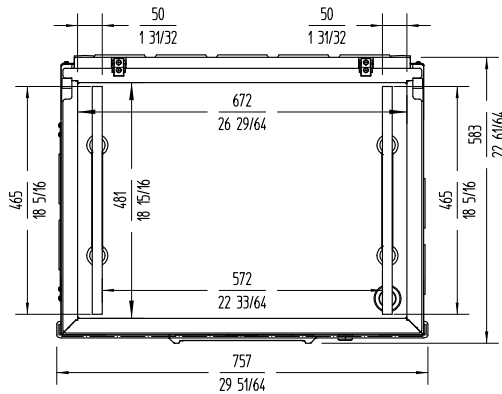
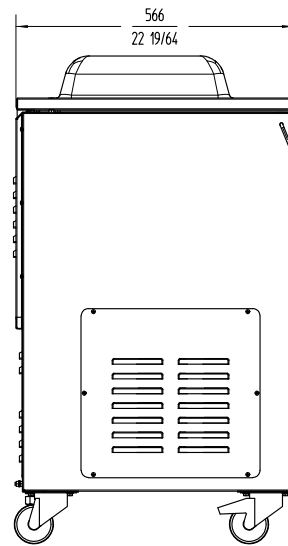
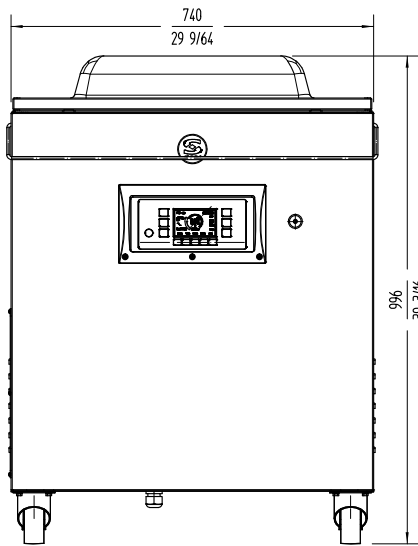

FOOD PRESERVATION AND SOUS-VIDE
COMMERCIAL VACUUM PACKING MACHINES

sammic | sammic.com
Food Service Equipment Manufacturer

Polígono Basarte, 1. phone +34 943 15 72 36
 20720 Azkoitia, Spain sales@sammic.com



Project	Date
Item	Qty
Approved	

product sheet
updated 03/12/2025